

SITS BEHIND PASSENGER SIDE WHEEL WELL

TERMINATION SCHEDULE

- 1) 10 GAUGE COPPER BUS GROUND TO FRAME SUPPORT (YELLOW INSULATION WITH BLACK TAPE)
- 2) LEFT REAR SIGNAL AND BOTH REVERSE LAMPS GROUND
- 3) LICENSE PLATE LAMP GROUND
- 4) FUEL TANK LEVEL SENDING UNIT GROUND
- 5) RIGHT REAR TURN SIGNAL GROUND AND DEMISTER GROUND
- 6) TAIL LAMP GROUNDS (LEFT AND RIGHT)
- 7) BREAK LAMP GROUNDS

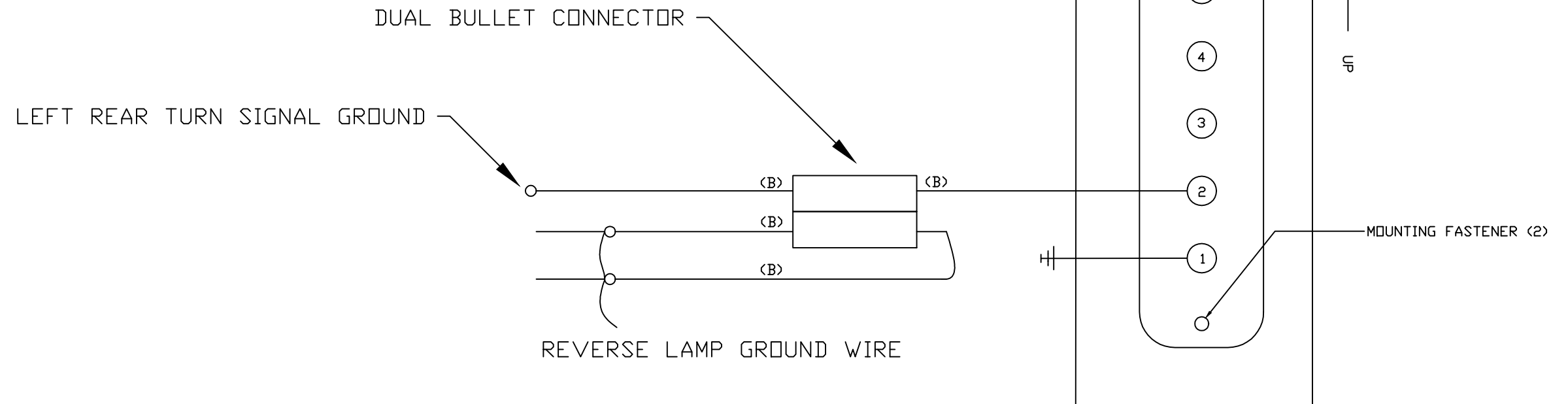

PROPRIETARY NOTICE

THIS DOCUMENT WHICH CONTAINS CONFIDENTIAL AND TRADE SECRET INFORMATION, IS THE PROPERTY OF CONTROLPOINT TECHNOLOGIES, INC., AND IS GIVEN TO THE RECEIVER IN CONFIDENCE. THE RECEIVER, BY RECEPTION AND RETENTION OF THE DOCUMENT, ACCEPTS THE DOCUMENT IN CONFIDENCE, AND AGREES THAT, EXCEPT IF AUTHORIZED IN WRITING BY CONTROLPOINT TECHNOLOGIES, INC., IT (1) NOT USE THE DOCUMENT OR ANY COPY THEREOF, OR THE CONFIDENTIAL TRADE SECRET INFORMATION THEREIN, (2) NOT COPY THE DOCUMENT, (3) DISCLOSE TO OTHERS EITHER THE DOCUMENT OR THE CONFIDENTIAL TRADE SECRET INFORMATION THEREIN, AND (4) UPON COMPLETION OF THE NEED TO RETAIN THE DOCUMENT, OR UPON DEMAND, RETURN THE DOCUMENT, ALL COPIES THEREOF, AND ALL MATERIAL COPIED THEREFROM. COPYRIGHT © CONTROLPOINT TECHNOLOGIES, INC., ALL RIGHTS RESERVED.

| REV | DESCRIPTION | DATE | CADD | ENGINEER | APPROVED |
|-----|----------------|---------|------|----------|----------|
| 0 | ORIGINAL ISSUE | 23JAN12 | JJH | JK | - |



DESIGN ENGINEERS: JIM KELLY
PEMBROKE, MA 02359

| | | | |
|-------------------------|---------------|--------|--------|
| 1969 TRIUMPH GT6 | | | |
| REAR BUS BAR #3 | | | |
| NON-REAL DIMENSIONS | DWG NO: GT6-3 | SHT: 3 | REV: 0 |